

Water Pressure Regulators

	Description	Supply pressure max. bar	Pressure range bar	Connection thread	Device	Page
miniature	for drinking water	10	0.1 ... 3.5 / 8.5	G $\frac{1}{4}$	R91	9.02
	preset, for drinking water	10	1 / 2 / 3... 8	G $\frac{1}{4}$	239K	9.03
	made of plastic	11	0 ... 1 / 9	G $\frac{1}{8}$ and G $\frac{1}{4}$	R25	9.04
	made of plastic	11	0 ... 1.8 / 9	G $\frac{1}{4}$ and G $\frac{3}{8}$	R45	9.04
standard	solid	40	0.5 ... 6	G $\frac{1}{2}$ - G $\frac{1}{4}$	RW	9.05
	female thread	60	0.2 ... 2 / 45	G $\frac{1}{4}$ - G2	RWI	9.06
	male thread	25	0.2 ... 2 / 20	R $\frac{3}{8}$ " - R $2\frac{1}{2}$ "	RWA	9.08
	flange	40	0.2 ... 2 / 20	DN 8-DN125	RWF	9.10
	stainless steel, flange	40	0.2 ... 2 / 20	DN15-DN50	RAF	9.12
	stainless steel, female thread	40	0.2 ... 2 / 20	G $\frac{1}{2}$ - G2	RAI	9.13
steam pressure regulator	spheroidal graphite iron	19	0.14 ... 1.7 / 9	G $\frac{1}{2}$ - G2, flange	RU	9.14
	red brass	17	0.14 ... 1.7 / 9	G $\frac{1}{2}$ - G2, flange	RU-R	9.14
	stainless steel	19	0.14 ... 1.7 / 9	G $\frac{1}{2}$ - G2, flange	RU-S	9.14



9

Water Pressure Regulators

Special



9

Description	Diaphragm miniature pressure regulator of small and lightweight design. All fluid-contact parts of R91-..K are approved by the FDA.	
Application area	food industry and water circulation, e.g. for dialysis devices	
Media	compressed air, non-corrosive gases, deionized water or other liquids.	
Supply pressure	max. 10 bar	Adjustment by plastic knob with snap-lock
Relieving function	non-relieving for drinking water (FDA), relieving for compressed air	Mounting position any
Gauge port	G $\frac{1}{8}$ on both sides of the body	
Temperature range	0 °C to 60 °C / 32 °F to 140 °F	
Material for	drinking water	compressed air
	Body: acetal	acetal
	Elastomer: acetal and nylon-reinforced nitrile	acetal and nylon-reinforced nitrile
	NBR/Buna-N	not FDA-approved
	Valve and o-ring: stainless steel and EPDM, FDA-approved	brass, nitrile and NBR/Buna-N

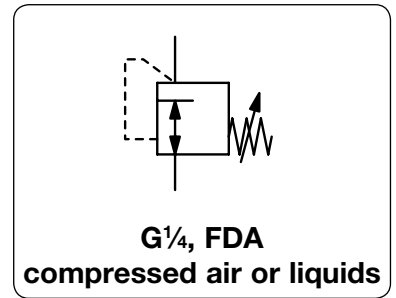

Dimensions			Flow rate		Connection	Pressure	Order
A	B	C	water	air	thread	range	number
mm	mm	mm	l/min*1	l/min*1	G	bar	

Press. regulator w. FDA approval for drinking water							P _i : max. 10 bar, EPDM non-relieving	R91-K
42	76	11	6	380	G $\frac{1}{4}$	0.1 ... 3.5	R91-02BK	
						0.1 ... 8.5	R91-02CK	

Press. regulator for compressed air							P _i : max. 10 bar, NBR/Buna-N relieving	R91
42	76	11		380	G $\frac{1}{4}$	0.1 ... 3.5	R91-02B	
						0.1 ... 8.5	R91-02C	



R91

Special options, add the appropriate letter		
NPT	connection thread	R91-02 . N

Accessories			
pressure gauge	Ø 40 mm, G $\frac{1}{8}$	0... 4 bar	MA4001-04
		0...10 bar	MA5002-10
mounting bracket	made of steel		BW30-02
mounting nut	made of plastic		M30x1,5K
	made of aluminium		M30x1,5A

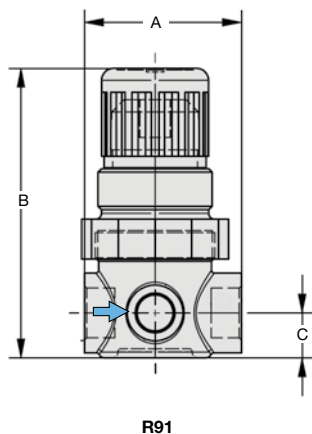

R91

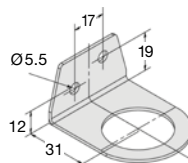

BW30-02

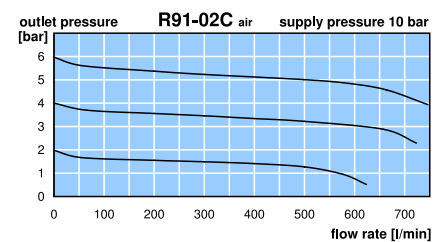
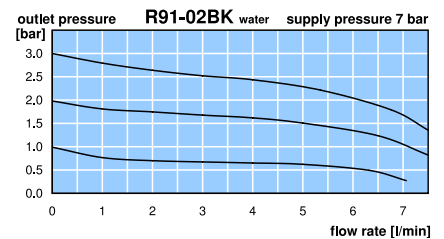

*1 supply pressure 1 bar above outlet pressure

General	In-Line pressure regulator with factory-set outlet pressure, reducing from e.g. 10 bar to 5 bar. The outlet pressure cannot be subsequently adjusted. This safeguards against tampering.
Description	regulator for drinking water conforms to the FDA, EU and DIN 50930-6, TÜV drinking water directives
Application	applications areas such as drinking water, food and medical industry
Supply pressure	max. 10 bar
Accuracy	± 0.3 bar, for compressed air P ₁ : 6 bar and 10 l/min
Temperature range	4 °C to 60 °C / 39.2 °F to 140 °F
Material	Body: Grivory® GV-5 FWA Inner parts: Stainless steel DIN 1.4404 / AISI 316L Elastomer: FPM

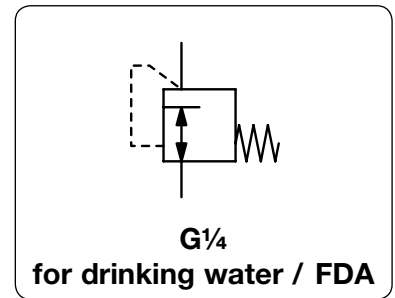

Dimensions			Flow rate	Supply	Connection	Outlet	Order
Ø A	B	A/F	water	pressure	thread	pressure	number
mm	mm	mm	l/min*1	max. bar	G	bar*2	

Regulator for drinking water				Grivory, accuracy *2	P ₁ : max. 10bar,	239K
34	52	17	3	10	G1/4	1 239K0210
			4			2 239K0220
			4			3 239K0230
			4			4 239K0240
			4			5 239K0250
			4			6 239K0260
			4			7 239K0270
			4			8 239K0280



239K

Special options, add the appropriate letter

NPT	connection thread	239K1 . . .
deviant pressure range	indicate on order	239K . . XX

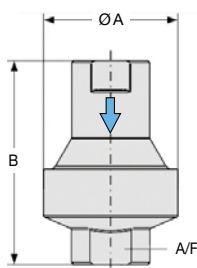

239K

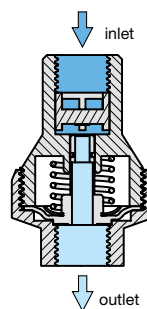

cross-section

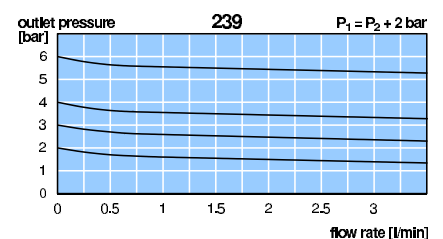

*1 P₁ = 10 bar; Δp = 0.8 bar

*2 Tolerance: < 4 bar ± 0.3 bar (air, P₀ = 6 bar, 10 l/min)
≥ 4 bar ± 10% (air, P₀ = 10 bar, 10 l/min)



Description	Miniature pressure regulator with diaphragm, designed for compressed air and water applications. All internal wetted sections are corrosion-resistant, lead free and without any brass components. Material approved by the NSF and FDA. Regulator for modular application with many integrated fixing holes.		
Media	compressed air, non-corrosive gases or water		
Supply pressure	max. 11 bar		
Adjustment	by plastic knob with snap-lock		
Relieving function	relieving for air, non-relieving for water		
Gauge port	G $\frac{1}{8}$ on both sides of R25,	G $\frac{1}{4}$ on both sides of R45, screw plugs supplied	
Mounting position	any		
Temperature range	0 °C to 50 °C / 32 °F to 122 °F		
Material	Body: glass fibre-reinforced acetal Inner valve: glass fibre-reinforced acetal	Elastomer: NBR/Buna-N	

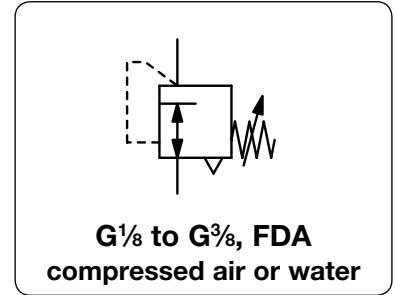

Dimensions			Flow rate		Connection	Pressure	Order no.	Order no. for
A	B	C	water	air	thread	range	for water	compressed air
mm	mm	mm	l/min*1	l/min*1	G	bar	non-relieving	relieving

Pressure regulator							supply pressure max. 11 bar		R25
40	78	12	3	150	G $\frac{1}{8}$	0...1.0	R25-010K	R25-010	R25-010
						0...1.8	R25-01AK	R25-01A	R25-01A
						0...4.0	R25-01BK	R25-01B	R25-01B
						0...9.0	R25-01CK	R25-01C	R25-01C
40	78	12	3	150	G $\frac{1}{4}$	0...1.0	R25-020K	R25-020	R25-020
						0...1.8	R25-02AK	R25-02A	R25-02A
						0...4.0	R25-02BK	R25-02B	R25-02B
						0...9.0	R25-02CK	R25-02C	R25-02C



R25

Pressure regulator for high flow							supply pressure max. 11 bar		R45
52	87	13	10	680	G $\frac{1}{4}$	0...1.8	R45-02AK	R45-02A	R45-02A
						0...4.0	R45-02BK	R45-02B	R45-02B
						0...9.0	R45-02CK	R45-02C	R45-02C
52	87	13	13	960	G $\frac{3}{8}$	0...1.8	R45-03AK	R45-03A	R45-03A
						0...4.0	R45-03BK	R45-03B	R45-03B
						0...9.0	R45-03CK	R45-03C	R45-03C



R45

Special options, add the appropriate letter
adjustment lock socket wrench adjustment, height 64 mm R25 only R25-0..T

Accessories		
pressure gauge	Ø 40 mm, 0...*2 bar, G $\frac{1}{8}$ Ø 50 mm, 0...*2 bar, G $\frac{1}{4}$	for R25 MA4001-..*2 for R45 MA5002-..*2
mounting bracket	made of steel	BW30-02
mounting nut	made of plastic made of aluminium	M30x1,5K M30x1,5A

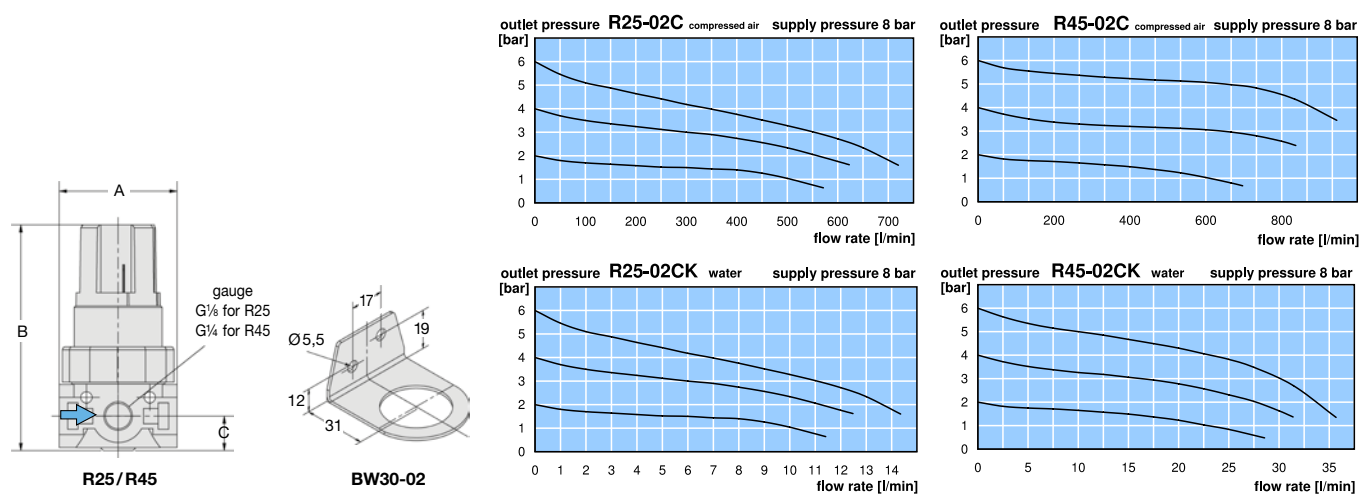

*1 at 8 bar supply pressure, 6 bar outlet pressure and 1 bar pressure drop, for water supply pressure 2 bar above outlet pressure
 *2 01 = 0...1 bar, 02 = 0...2.5 bar, 04 = 0...4 bar, 10 = 0...10 bar

Description	Pressure regulator with diaphragm for drinking water. Regulator RW1 is of low cost and small size. Regulator RW2 features an indicator of the preset outlet pressure inside its knob and a filter.	
Media	water	
Supply pressure	max. 40 bar at RW1, max. 25 bar at RW2	
Adjustment	by plastic knob	
Relieving function	non-relieving	
Gauge port	G $\frac{1}{4}$ on the outlet side, slantwise outgoing, screw plug supplied	
Mounting position	any	
Temperature range	-10 °C to 85 °C / 14 °F to 185 °F	
Material	Body: sandblasted brass Elastomer: NBR/Buna-N	Adjustment knob: acrylic plastic Inner valve: brass and stainless steel

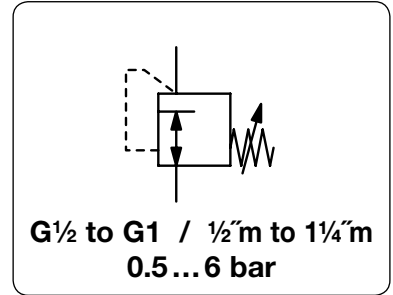

Dimensions			Nominal size	K _v -value	Flow rate water	Connection thread	P ₁ max.	Pressure range	Order number
A	B	C	DN	(m ³ /h)	l/min*1	G / nipple	bar	bar	

Pressure regulator for water									supply: max. 40 bar at RW1, max. 25 bar at RW2, non-relieving, brass	RW
68	122	18	15	2.5	25	G $\frac{1}{2}$	40	0.5...6		RW1-04
78	134	18	20	3.5	45	G $\frac{3}{4}$				RW1-06
81	137	20	25	5.8	80	G1				RW1-08
140	152	49	15	2.8	25	$\frac{1}{2}$ "m	25	0.5...6		RW2-04
160	173	55	20	4.2	45	$\frac{3}{4}$ "m				RW2-06
185	175	57	25	6.8	80	1"m				RW2-08
194	178	60	32	11	120	1 $\frac{1}{4}$ "m				RW2-10



RW1



RW2

Accessories

pressure gauge	Ø 50 mm, 0... 6 bar, G $\frac{1}{4}$	for RW . -04	MA5002-06
	Ø 63 mm, 0... 6 bar, G $\frac{1}{4}$	for RW . -06 to -10	MA6302-06

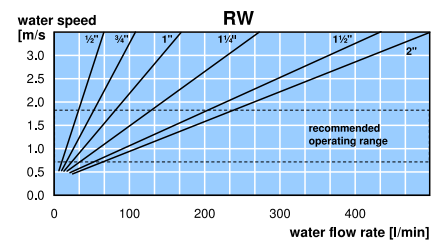
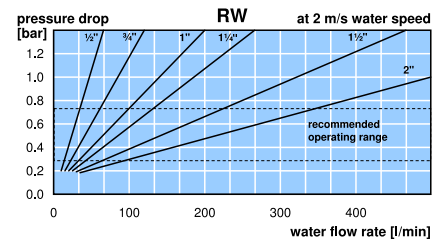
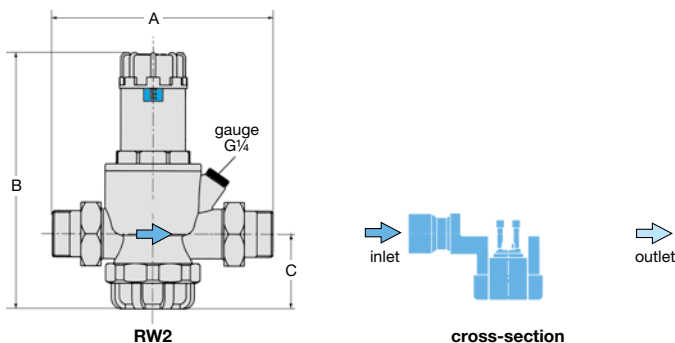
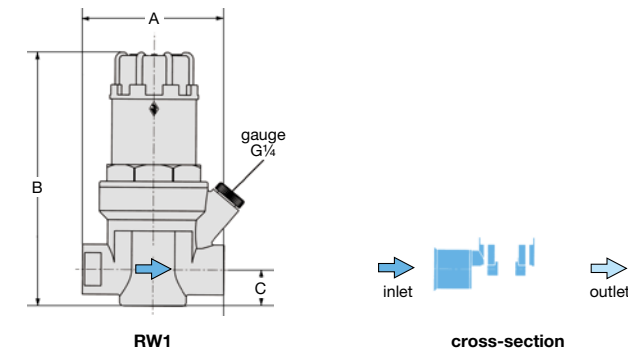

*1 at 2 m/s water speed

Gauges: see chapter for measuring devices

PDF CAD
www.aircom.net



Order example:
RW1-04

Special



9

Description Regulator independent of inlet pressure, made of gunmetal, with strainer of stainless steel. Regulators up to 10 bar outlet pressure equipped with diaphragm, all others are piston-operated.

Drinking water particularly all regulators RWI...C with outlet range 1.5 ...6 bar

Media preferably water or drinking water, but also compressed air, neutral liquids and non-corrosive gases. Especially suitable for compressed air are regulators RWI...D. It has to be considered that these regulators are non-relieving.

Pressure difference 1 bar, between inlet and outlet pressure

Reduction ratio between supply and outlet pressure should not be greater than:
20:1 for RWI...A, 10:1 for RWI...D, 6:1 for RWI...G/H, 3:1 for RWI...I

Gauge port G¼ on both sides of the body for outlet pressure, ports are closed with screw plugs.

ATEX according to ATEX94/9EG, EN1127, EN13463 for zone 1, 2, 21 and 22

PED according to EU directives DGRL/PED for liquids and gases of group 2

Temperature range 0 °C to 80 °C / 32 °F to 176 °F

Material see opposite page

Mounting position any, preferably vertical

Screw standard according to DIN ISO 228

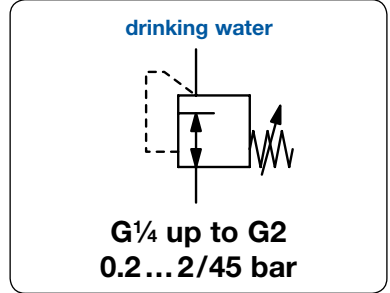

Dimensions			Flow rate	Kvs-	Nominal	Connection	Pressure		Order
A	B	C	recommended	value	size	thread	inlet	outlet	number
mm	mm	mm	(m³/h)*1	(m³/h)*2	DN	G	max. bar	bar	

Regulator with female thread						gunmetal, NBR/Buna-N drinking water: RWI...C	RWI		
70	186	46	0.2	0.5	DN 8	G¼	25	0.2 ... 2	RWI-02A
	167	47					25	1.5 ... 8	RWI-02D
	188	47					40	2.0 ... 20	RWI-02H
	191	48					60	20 ... 45	RWI-02I
70	186	46	0.2	0.6	DN 10	G¾	25	0.2 ... 2	RWI-03A
	167	47					25	1.5 ... 8	RWI-03D
	188	47					40	2.0 ... 20	RWI-03H
	191	48					60	20 ... 45	RWI-03I
85	154	27	1.3	2.9	DN 15	G½	16	0.2 ... 2	RWI-04A
	168	27	1.3	2.9			25	0.5 ... 4	RWI-04B
	168	27	1.3	2.9			25	1.5 ... 6	RWI-04C
	189	47	0.5	1.2			25	1.5 ... 8	RWI-04D
	163	27	1.3	2.9			25	1.5 ... 10	RWI-04E
	182	27	1.3	2.9			25	1.5 ... 12	RWI-04F
	233	27	1.3	2.9			25	2.0 ... 20	RWI-04G
	229	47	0.5	1.2			40	2.0 ... 20	RWI-04H
	218	47	0.5	1.2			60	20 ... 45	RWI-04I
95	157	27	2.3	3.9	DN 20	G¾	16	0.2 ... 2	RWI-06A
	169	27	2.3	3.8			25	0.5 ... 4	RWI-06B
	169	27	2.3	3.9			25	1.5 ... 6	RWI-06C
	190	47	0.6	1.3			25	1.5 ... 8	RWI-06D
	164	27	2.3	3.9			25	1.5 ... 10	RWI-06E
	182	27	2.3	3.9			25	1.5 ... 12	RWI-06F
	234	27	2.3	3.9			25	2.0 ... 20	RWI-06G
	229	47	0.6	1.3			40	2.0 ... 20	RWI-06H
	218	47	0.6	1.3			60	20 ... 45	RWI-06I
105	156	29	3.6	5.4	DN 25	G1	16	0.2 ... 2	RWI-08A
	105	170	29	5.2			25	0.5 ... 4	RWI-08B
	105	170	29	5.4			25	1.5 ... 6	RWI-08C
	95	242	56	0.7			25	1.5 ... 8	RWI-08D
	105	164	29	5.4			25	1.5 ... 10	RWI-08E
	105	184	29	5.4			25	1.5 ... 12	RWI-08F
	105	235	29	5.4			25	2.0 ... 20	RWI-08G
	95	256	55	0.7			40	2.0 ... 20	RWI-08H

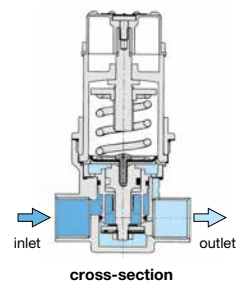
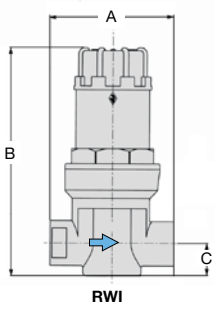
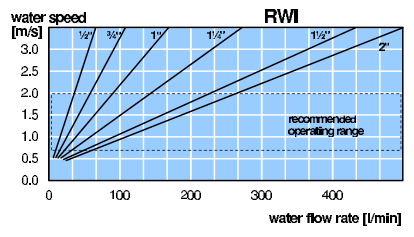
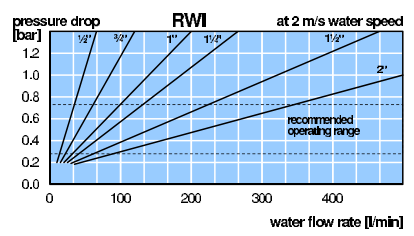

*1 at 2 m/s water speed *2 for compressed air the flow is 70 times greater

		Material									
Regulator	RW	RWI...A	RWI...B	RWI...C	RWI...D	RWI...E	RWI...F	RWI...G	RWI...H	RWI...J	
Nominal size	DN	DN 8-10	DN 15-80	DN 15-50	DN 15-50	DN 8-50	DN 15-50	DN 15-50	DN 15-50	DN 8-50	DN 8-20
Body	all	gunmetal CnSn5Zn5Pb2-C-GS / CC499K (Rg5)									
Spring cage	< DN 32	Ms (< DN 25)	PA	Ms	PA	Ms (< DN 25)	Ms			Ms (< DN 25)	
	> DN 40	-	Rg	GG	GG (> DN 32)	GG				GG (> DN 32)	
Seals	all	NBR/Buna N									
Diaphragm	< DN 25	CR	NBR/Buna N		CR	NBR/Buna-N		piston / NBR/Buna-N			
	> DN 32	NBR/Buna N		CR	NBR/Buna-N		piston / NBR/Buna-N				
Spring cage	< DN 32	Ms	Ms, SS, Ho		Ms	Ms, SS, Ho (< DN 25 Ms)			Ms	Ms	
	> DN 40	-	Ms, SS		Ms, Rg, SS	Ms, SS			Ms, Rg, SS	-	
Reg. assembly	< DN 32	cartridge			valve seat		cartridge		valve seat		
removable	> DN 40				valve seat						
Legend:		Ms: brass	SS: stainless steel	Rg: gunmetal	GG: grey cast iron	Ho: Hostaform C					

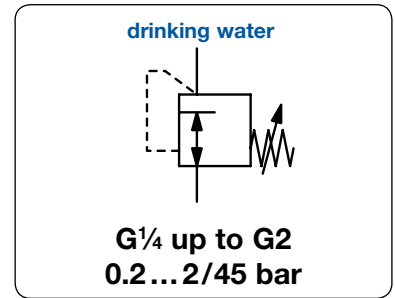

Dimensions			Flow rate	Kvs-	Nominal	Connection	Pressure		Order
A	B	C	recommended	value	size	thread	inlet	outlet	number
mm	mm	mm	(m³/h)*1	(m³/h)*2	DN	G	max. bar	bar	

Regulator with female thread							gunmetal, NBR/Buna-N drinking water: RWI...C	RWI		
120	174	47	5.8	6.1	DN 32	G1¼	16	0.2 ... 2	2	RWI-10A
120	187	47	5.8	6.0			25	0.5 ... 4	4	RWI-10B
120	186	47	5.8	6.1			25	1.5 ... 6	6	RWI-10C
104	323	61	3.0	4.2			25	1.5 ... 8	8	RWI-10D
120	182	47	5.8	6.1			25	1.5 ... 10	10	RWI-10E
120	200	47	5.8	6.1			25	1.5 ... 12	12	RWI-10F
120	252	47	5.8	6.1			25	2.0 ... 20	20	RWI-10G
104	385	61	3.0	4.2			40	1.5 ... 20	20	RWI-10H
150	371	60	9.0	9.0	DN 40	G1½	16	0.2 ... 2	2	RWI-12A
150	301	60	9.0	9.0			25	0.5 ... 4	4	RWI-12B
150	293	52	9.0	9.0			25	1.5 ... 6	6	RWI-12C
108	323	61	3.2	4.5			25	1.5 ... 8	8	RWI-12D
150	365	52	9.0	9.0			25	1.5 ... 10	10	RWI-12E
150	361	60	9.0	9.0			25	1.5 ... 12	12	RWI-12F
150	386	60	9.0	9.0			25	2.0 ... 20	20	RWI-12G
108	392	61	3.2	4.5			40	1.5 ... 20	20	RWI-12H
160	371	60	14	13	DN 50	G2	16	0.2 ... 2	2	RWI-16A
160	301	60	14	13			25	0.5 ... 4	4	RWI-16B
160	293	52	14	13			25	1.5 ... 6	6	RWI-16C
147	378	72	6.9	7.2			25	1.5 ... 8	8	RWI-16D
160	365	52	14	13			25	1.5 ... 10	10	RWI-16E
160	361	60	14	13			25	1.5 ... 12	12	RWI-16F
160	386	60	14	13			25	2.0 ... 20	20	RWI-16G
147	421	72	6.9	7.2			40	1.5 ... 20	20	RWI-16H



RWI-10...16D RWI-10...16H



RWI-12...16A RWI-12...16B / C / E



RWI-12...16F / G

Special options, add the appropriate letter

NPT	connection thread	RWI-. . .N
Elastomer	CR: C FKM: V	RWI-. . .V
for different media	warm-, hot-, and see water, acids, bases, oil, petrol glue, food, foam, gases etc.	RWI-. . .X

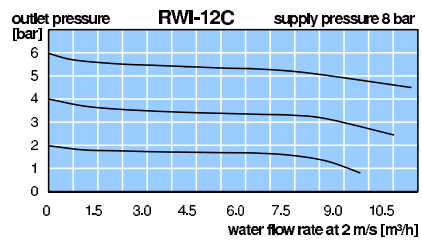
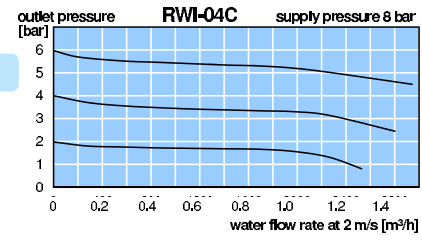
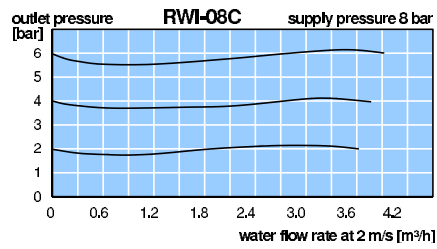
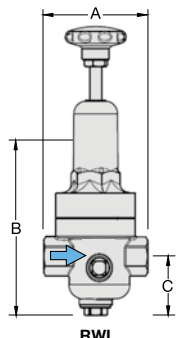

Accessories

pressure gauge Ø 50 mm, rear 0...^{*3} bar, G¼ up to G½ MA5002-..^{*3}
 Ø 63 mm, rear 0...^{*3} bar, G¼ from G¾ MA6302-..^{*3}



*1 at 2 m/s water speed *2 for compressed air the flow is 70 times greater
^{*3} 02 = 0...2 bar, 04 = 0...4 bar, 06 = 0...6 bar, 10 = 0...10 bar, 16 = 0...16 bar, 25 = 0...25 bar, 60 = 0...60 bar

Description Regulator independent of inlet pressure, made of gunmetal, with strainer of stainless steel. Regulators up to 10 bar outlet pressure equipped with diaphragm, all others are piston-operated. particularly all regulators RWA-...C with pressure range 1.5 ...6 bar. Regulators with DN 15 up to DN 25 have the same constructions dimensions as D06F from Honeywell, according to DVGW up to DN 32.

Drinking water  

Media preferably water or drinking water, but also compressed air, neutral liquids and non-corrosive gases. It has to be considered that these regulators are non-relieving.

Pressure difference 1 bar, between inlet and outlet pressure

Gauge port G $\frac{1}{4}$ on both sides of the body for outlet pressure, ports are closed with screw plugs.

Mounting position any, preferably vertical

ATEX according to ATEX94/9EG, EN1127, EN13463 for zone 1, 2, 21 and 22

PED according to EU directives DGRL/PED for liquids and gases of group 2

Temperature range 0 °C to 80 °C / 32 °F to 176 °F

Material see opposite page

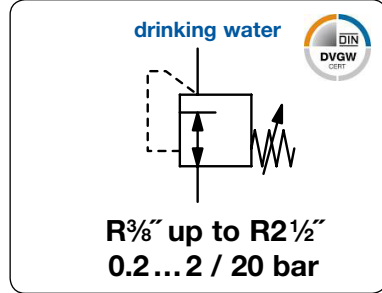

Dimensions			Flow rate	K _{vs}	Nominal Connection	Pressure		Order	
A	B	C	recommended	value	size	thread	inlet	outlet	number
mm	mm	mm	(m ³ /h)*1	(m ³ /h)*2	DN	R	max. bar	bar	

Regulator with male thread							gunmetal, NBR/Buna-N	RWA	
							drinking water: RWA-...C		
137	154	27	1,3	2.9	DN 10	3/8"	16	0.2 ... 2	RWA-03A
	163						25	0.5 ... 4	RWA-03B
	168						25	1.5 ... 6	RWA-03C
	163						25	1.5 ... 10	RWA-03E
	182						25	1.5 ... 12	RWA-03F
	233						25	2.0 ... 20	RWA-03G
137	154	27	1,3	2.9	DN 15	1/2"	16	0.2 ... 2	RWA-04A
	163						25	0.5 ... 4	RWA-04B
	168						25	1.5 ... 6	RWA-04C
	163						25	1.5 ... 10	RWA-04E
	182						25	1.5 ... 12	RWA-04F
	233						25	2.0 ... 20	RWA-04G
141	156	27	2,3	3.9	DN 20	3/4"	16	0.2 ... 2	RWA-06A
	163						25	0.5 ... 4	RWA-06B
	168						25	1.5 ... 6	RWA-06C
	163						25	1.5 ... 10	RWA-06E
	182						25	1.5 ... 12	RWA-06F
	233						25	2.0 ... 20	RWA-06G
161	155	29	3,6	5.4	DN 25	1"	16	0.2 ... 2	RWA-08A
	164						25	0.5 ... 4	RWA-08B
	168						25	1.5 ... 6	RWA-08C
	164						25	1.5 ... 10	RWA-08E
	182						25	1.5 ... 12	RWA-08F
	233						25	2.0 ... 20	RWA-08G
177	156	47	5,8	6.1	DN 32	1 1/4"	16	0.2 ... 2	RWA-10A
	219						25	0.5 ... 4	RWA-10B
	222						25	1.5 ... 6	RWA-10C
	219						25	1.5 ... 10	RWA-10E
	234						25	1.5 ... 12	RWA-10F
	252						25	2.0 ... 20	RWA-10G

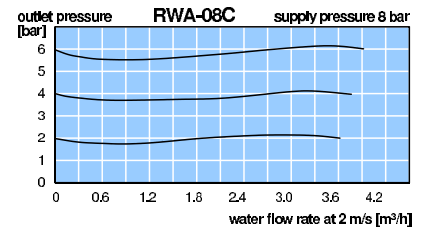
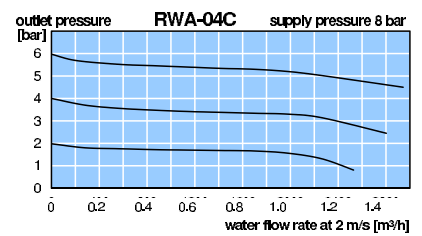
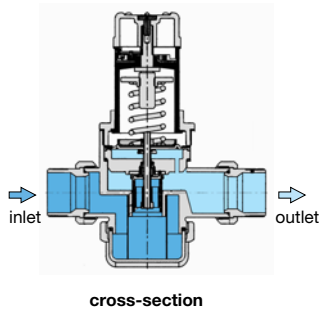
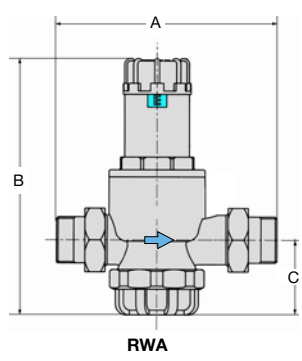

*1 at 2 m/s water speed *2 for compressed air the flow is 70 times greater

Regulator	Material						
	RW	RWA-..A	RWA-..B	RWA-..C	RWA-..E	RWA-..F	RWA-..G
Nominal size	DN	DN 10-65	DN 15-65	DN 10-65	DN 15-65	DN 15-100	DN 10-65
Body	all	gunmetal CnSn5ZN5Pb2-C-GS / CC499K (Rg5)					
Spring cage	< DN 32	PA	Ms	PA	Ms	Ms (< DN 25)	Ms (< DN 25)
	> DN 40	Rg	GG	GG	GG	GG (> DN 32)	GG (> DN 32)
Seals	all	NBR/Buna N					
Diaphragm	< DN 25	NBR/Buna N			NBR/Buna-N		
	> DN 32	NBR/Buna N			piston / NBR/Buna-N		
Inner valve	< DN 32	Ms, SS, Ho			Ms, SS, Ho (< DN 25 Ms)		
	> DN 40	Ms, SS			Ms, SS		
Reg. assembly removable	< DN 32	cartridge				valve seat	
	> DN 40					valve seat	

Legend: **Ms**: brass **SS**: stainless steel **Rg**: gunmetal **GG**: grey cast iron **Ho**: Hostaform C **NBR/Buna-N**: nitrile rubber

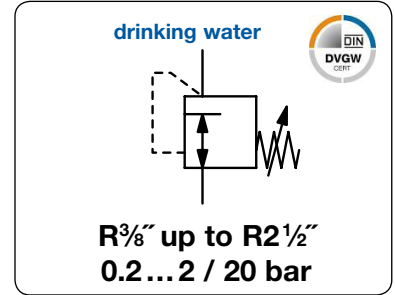

Dimensions			Flow rate	K _{vs}	Nominal Connection		Pressure		Order
A	B	C	recommended	value	size	thread	inlet	outlet	number
mm	mm	mm	(m ³ /h)*1	(m ³ /h)*2	DN	R	max. bar	bar	

Regulator with male thread							gunmetal, NBR/Buna-N drinking water: RWA-..C	RWA	
210	370	59	9,0	9,0	DN 40	1½"	16	0.2 ... 2	RWA-12A
	301	51					25	0.5 ... 4	RWA-12B
	293	51					25	1.5 ... 6	RWA-12C
	361	51					25	1.5 ... 10	RWA-12E
	361	51					25	1.5 ... 12	RWA-12F
	386	51					25	2.0 ... 20	RWA-12G
210	372	61	14	13	DN 50	2"	16	0.2 ... 2	RWA-16A
	372	61					25	0.5 ... 4	RWA-16B
	294	53					25	1.5 ... 6	RWA-16C
	363	53					25	1.5 ... 10	RWA-16E
	364	53					25	1.5 ... 12	RWA-16F
	388	53					25	2.0 ... 20	RWA-16G
273	394	68	24	20	DN 65	2½"	16	0.2 ... 2	RWA-20A
	324						25	0.5 ... 4	RWA-20B
	324						25	1.5 ... 6	RWA-20C
	392						25	1.5 ... 10	RWA-20E
	384						25	1.5 ... 12	RWA-20F
	408						25	2.0 ... 20	RWA-20G



Special options, add the appropriate letter			
NPT	connection thread		RWA-.. .N
Elastomer	CR: C	FKM: V	RWA-.. .V
for different media	warm-, hot-, and see water, acids, bases, oil, petrol glue, food, foam, gases etc.		RWA-.. .X

Accessories			
pressure gauge	Ø 50 mm, rear 0... ^{*3} bar, G¼	up to G½	MA5002-..^{*3}
	Ø 63 mm, rear 0... ^{*3} bar, G¼	from G¾	MA6302-..^{*3}

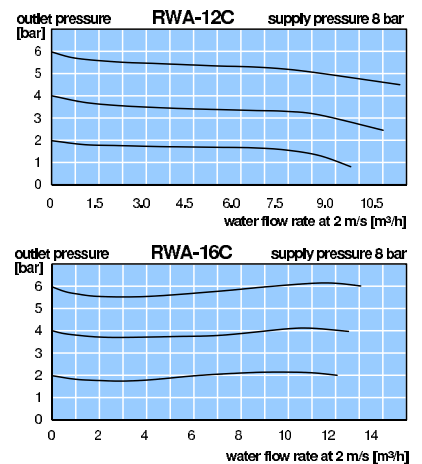
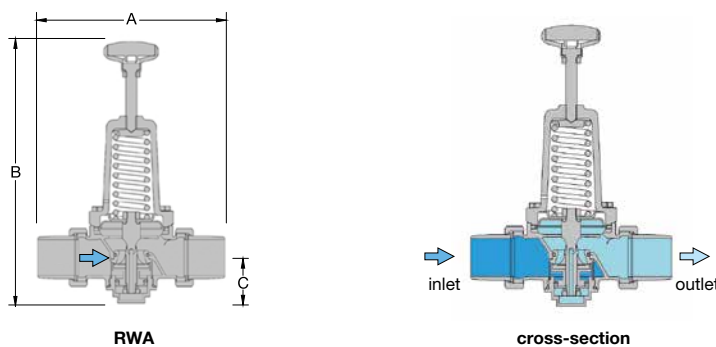

*1 at 2 m/s water speed *2 for compressed air the flow is 70 times greater
^{*3} 02 = 0...2 bar, 04 = 0...4 bar, 06 = 0...6 bar, 10 = 0...10 bar, 16 = 0...16 bar, 25 = 0...25 bar

Description Regulator independent of inlet pressure, made of gunmetal, with strainer of stainless steel. Regulators up to 10 bar outlet pressure equipped with diaphragm, all others are piston-operated.

Drinking water particularly all regulators RWF-..C with pressure range 1.5 ...6 bar.

Media preferably water or drinking water, but also compressed air, neutral liquids and non-corrosive gases. It has to be considered that these regulators are non-relieving.

Pressure difference 1 bar, between inlet and outlet pressure

Gauge port G $\frac{1}{4}$ on both sides of the body for outlet pressure, ports are closed with screw plugs.

Mounting position any, preferably vertical

ATEX according to ATEX94/9EG, EN1127, EN13463 for zone 1, 2, 21 and 22

PED according to EU directives DGRL/PED for liquids and gases of group 2

Flanges according to DIN 1092. length according to DIN558-1

Temperature range 0 °C to 80 °C / 32 °F to 176 °F

Material see opposite page

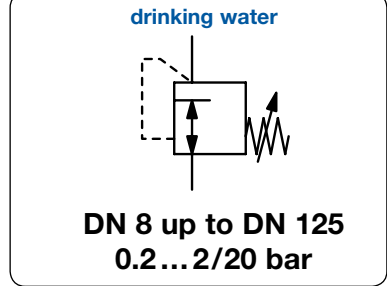

Dimensions				Flow rate	K _{vs} -	Nominal	Pressure		Order
A	B	C	D	recommended	value	size	inlet	outlet	number
mm	mm	mm	mm	(m ³ /h)*1	(m ³ /h)	DN	max. bar	bar	

Pressure regulator with flange							gunmetal, NBR/Buna N, w/o gauge drinking water: RWF-..C	RWF		
130	178	48	80	0.2	0.5	DN 8	25	0.8 ... 8	RWF-02D	
							40	1.5 ... 20	RWF-02G	
				0.2	0.5	DN 10	25	0.8 ... 8	RWF-03D	
							40	1.5 ... 20	RWF-03G	
130	175	48	95	1.3	2.9	DN 15	16	0.2 ... 2	RWF-04A	
							25	0.5 ... 4	RWF-04B	
								1.5 ... 6	RWF-04C	
								1.5 ... 10	RWF-04E	
								1.5 ... 12	RWF-04F	
								2.0 ... 20	RWF-04G	
150	183	53	105	2.3	3.9	DN 20	16	0.2 ... 2	RWF-06A	
							25	0.5 ... 4	RWF-06B	
								1.5 ... 6	RWF-06C	
								1.5 ... 10	RWF-06E	
								1.5 ... 12	RWF-06F	
								2.0 ... 20	RWF-06G	
160	185	58	115	3.6	5.4	DN 25	16	0.2 ... 2	RWF-08A	
							25	0.5 ... 4	RWF-08B	
								1.5 ... 6	RWF-08C	
								1.5 ... 10	RWF-08E	
								1.5 ... 12	RWF-08F	
								2.0 ... 20	RWF-08G	
180	197	70	140	5.8	6.1	DN 32	16	0.2 ... 2	RWF-10A	
							25	0.5 ... 4	RWF-10B	
								1.5 ... 6	RWF-10C	
								1.5 ... 10	RWF-10E	
								1.5 ... 12	RWF-10F	
								2.0 ... 20	RWF-10G	
200	386	75	150	9.0	9.0	DN 40	16	0.2 ... 2	RWF-12A	
							25	0.5 ... 4	RWF-12B	
								1.5 ... 6	RWF-12C	
								1.5 ... 10	RWF-12E	
								1.5 ... 12	RWF-12F	
								2.0 ... 20	RWF-12G	



RWF-02...08D / G



RWF-...10...16G



RWF-24A
Zubehör Manometer

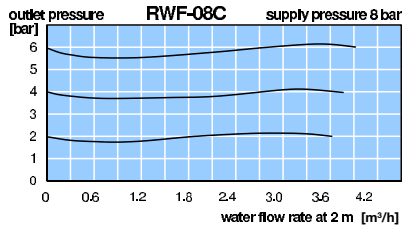
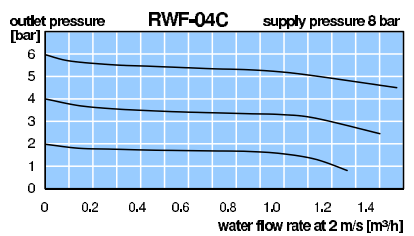
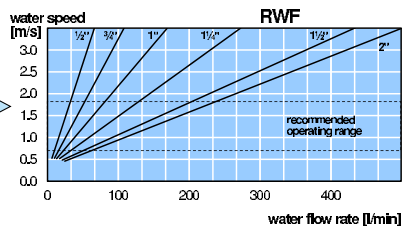
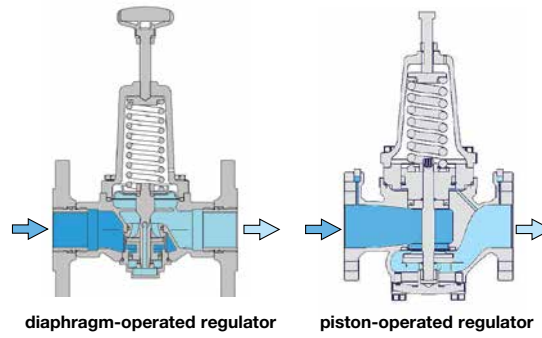

*1 at 2 m/s water speed * for compressed air the flow is 70 times greater

Regulator Nominal size	RW DN	Material						
		RWF-..A DN 8-10	RWF-..B DN 15-80	RWF-..C DN 15-125	RWF-..D DN 15-125	RWF-..E DN 15-125	RWF-..F DN 15-100	RWF-..G DN 8-80
Body	all	gunmetal CnSn5Zn5Pb2-C-GS / CC499K (Rg5)						
Spring cage	< DN 32 > DN 40	Ms (< DN 25) -	PA Rg	Ms	PA	Ms	Ms (< DN 25) GG (> DN 32)	
Seals	all	NBR/Buna-N						
Diaphragm	< DN 25 > DN 32	CR	NBR/Buna-N				piston / NBR/Buna-N	
Inner valve	< DN 32 > DN 40	Ms	Ms, SS, Ho			Ms, SS, Ho (< DN 25 Ms) Ms, SS		
Reg. assembly removable	< DN 32 > DN 40	cartridge				valve seat		

Legend: Ms: brass SS: stainless steel Rg: gunmetal GG: grey cast iron Ho: Hostaform C CR: chloroprene rubber, NBR/Buna-N: nitrile rubber

drinking water

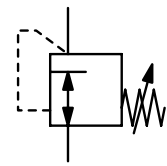

DN 15 up to DN 125
0.2... 2/20 bar

Dimensions				Flow rate	Kvs-	Nominal	Pressure		Order
A	B	C	D	recommended	value	size	inlet	outlet	number
mm	mm	mm	mm	(m³/h)*1	(m³/h)	DN	max. bar	bar	

Pressure regulator with flange

gunmetal, NBR/Buna N, w/o gauge
drinking water: RWF-..C

RWF

230	394	83	165	14	13	DN 50	16	0.2 ... 2	RWF-16A
324							25	0.5 ... 4	RWF-16B
324								1.5 ... 6	RWF-16C
396								1.5 ... 10	RWF-16E
384								1.5 ... 12	RWF-16F
411								2.0 ... 20	RWF-16G
290	420	93	185	24	20	DN 65	16	0.2 ... 2	RWF-20A
349							25	0.5 ... 4	RWF-20B
349								1.5 ... 6	RWF-20C
418								1.5 ... 10	RWF-20E
411								1.5 ... 12	RWF-20F
429								2.0 ... 20	RWF-20G
310	427	100	200	26	24	DN 80	16	0.2 ... 2	RWF-24A
	518	136		60	60			0.5 ... 4	RWF-24B
	356	100		26	24			1.5 ... 6	RWF-24C
	518	136		60	60			1.5 ... 6	RWF-24E
	521			60	60			3.0 ... 10	RWF-24F
	545			60	60		25	4.0 ... 12	RWF-24G
	436			24	24		25	2.0 ... 20	RWF-24H
350	540	140	200	80	80	DN 100	16	0.5 ... 4	RWF-32B
	540							1.5 ... 6	RWF-32C
	542							3.0 ... 10	RWF-32E
	600	135						4.0 ... 12	RWF-32F
400	730	165	270	130	130	DN 125	16	0.5 ... 4	RWF-40B
	540							1.5 ... 6	RWF-40C
	542							3.0 ... 10	RWF-40E



RWF-.. 24B / C / E
accessories: pressure gauge



RWF-.. 12...16F / G
accessories: pressure gauge



RWF-24F
accessories: pressure gauge

Special options, add the appropriate letter

Elastomer	EPDM: E	CR: C	FKM: V	RWF-.. .V
flange connection	ANSI			RWF-.. .F2
for different media	warm-, hot-, and see water, acids, bases, oil, petrol			RWF-.. .X
	glue, food, foam, gases etc.			

Accessories

pressure gauge Ø 63 mm, vertical 0...*2 bar, G¼ MT6302-..*2

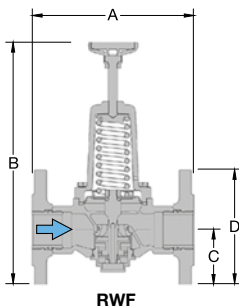

RWF

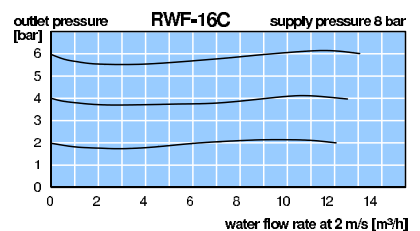
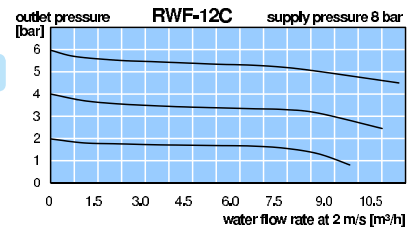
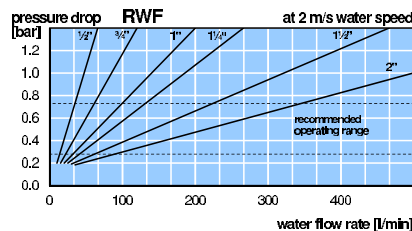

*1 at 2 m/s water speed * for compressed air the flow is 70 times greater
*2 02 = 0...2 bar, 04 = 0...4 bar, 06 = 0...6 bar, 10 = 0...10 bar, 16 = 0...16 bar, 25 = 0...25 bar

Gauges: see chapter for measuring devices

PDF CAD
www.aircom.net



Order example:
RWF-16A

Flange Pressure Regulator Made of Stainless Steel Throughout

RAF

Description	Pressure regulator made of stainless steel throughout. Even when spindle is unscrewed the indicated minimum outlet pressure is existent. Inner parts are replaceable. With stainless-steel dirt-trap / strainer
Medium	aggressive liquids, compressed air or non-corrosive gases. Not suitable for steam!
Supply pressure	see chart, max. 40 bar
Minimum press. difference	$P_1 : P_2 = 1$ bar
Adjustment	with hexagon socket, with locknut
Relieving function	non-relieving
Gauge port	G $\frac{1}{4}$ on both sides of the body, one screw plug supplied
Mounting position	any, preferably vertical
Flange	according DIN 1092, overall length according DIN 558-1
Temperature range	0 °C to 190 °C / 32 °F to 374 °F media and ambient temperature
Material	Body, spring cage, inner valve: stainless steel 1.4408 / V4A / 316 L Elastomer and seals: FKM / FPM

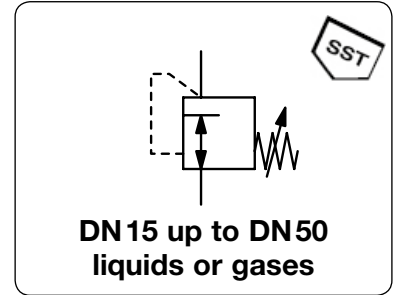

Dimensions			K _v -value (m ³ /h)*1	Flow rate water l/min*2	Supply pressure max. bar	Mounting flange DN	Pressure range bar	Order number
A	B	C						

Regulator with flange

for liquids, supply pressure max. 25/40 bar
non-relieving, 1.4408 / V4A / 316L, FKM

RAF

130	137	95	2.9	50	25	DN 15	0.2 ... 2	RAF-04A	
	118	118						0.5 ... 4	RAF-04B
	118	118						1.5 ... 6	RAF-04C
	118	118						1.5 ... 10	RAF-04D
	136	136						2.0 ... 20	RAF-04F
150	137	105	3.9	65	25	DN 20	0.2 ... 2	RAF-06A	
	118	118						0.5 ... 4	RAF-06B
	118	118						1.5 ... 6	RAF-06C
	118	118						1.5 ... 10	RAF-06D
	137	137						2.0 ... 20	RAF-06F
160	150	115	5.4	90	25	DN 25	0.2 ... 2	RAF-08A	
	118	118						0.5 ... 4	RAF-08B
	118	118						1.5 ... 6	RAF-08C
	118	118						1.5 ... 10	RAF-08D
	137	137						2.0 ... 20	RAF-08F
180	150	140	6.1	102	25	DN 32	0.2 ... 2	RAF-10A	
	118	118						0.5 ... 4	RAF-10B
	118	118						1.5 ... 6	RAF-10C
	118	118						1.5 ... 10	RAF-10D
	137	137						2.0 ... 20	RAF-10F
200	269	150	9.0	150	25	DN 40	0.2 ... 2	RAF-12A	
	219	219						0.5 ... 4	RAF-12B
	219	219						1.5 ... 6	RAF-12C
	219	219						1.5 ... 10	RAF-12D
	247	247						2.0 ... 20	RAF-12F
230	269	165	13	216	25	DN 50	0.2 ... 2	RAF-16A	
	219	219						0.5 ... 4	RAF-16B
	219	219						1.5 ... 6	RAF-16C
	219	219						1.5 ... 10	RAF-16D
	247	247						2.0 ... 20	RAF-16F

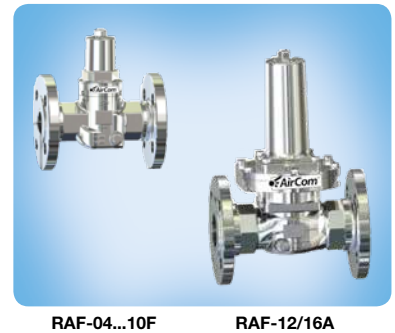
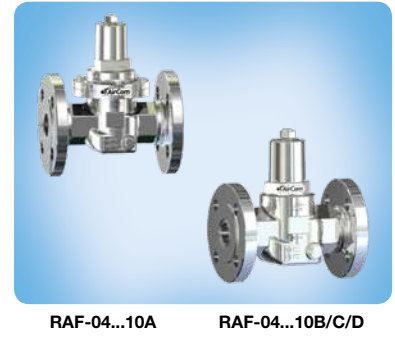

Accessories

SST pressure gauge	Ø 50 mm, 0... ^{*3} bar, G $\frac{1}{4}$, for DN 15	MS5002-... ^{*3}
	Ø 63 mm, 0... ^{*3} bar, G $\frac{1}{4}$, and all the rest of them	MS6302-... ^{*3}

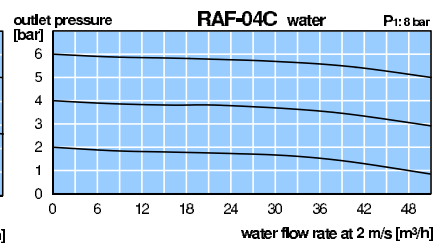
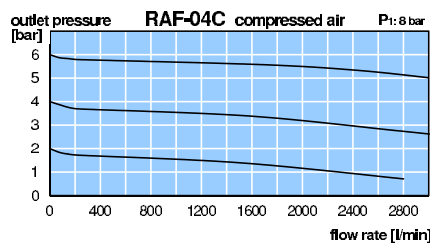
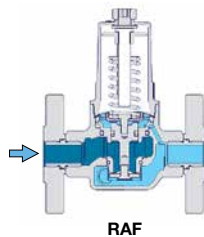
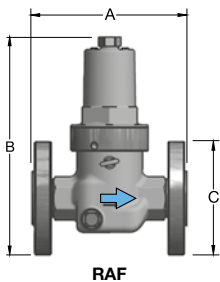

*1 at 2 m/s water speed *2 for compressed air the flow is 70 times greater
*3 02 = 0...2 bar, 04 = 0...4 bar, 06 = 0...6 bar, 10 = 0...10 bar, 16 = 0...16 bar, 25 = 0...25 bar

Gauges: see chapter for measuring devices

PDF CAD
www.aircom.net

Order example:
RAF-04A

Spezial
9

Pressure Regulator Made of Stainless Steel Throughout

RAI

Description	Pressure regulator made of stainless steel throughout. Even when spindle is unscrewed the indicated minimum outlet pressure is existent. Inner parts are replaceable. With stainless-steel dirt-trap / strainer
Medium	aggressive liquids, compressed air or non-corrosive gases. Not suitable for steam!
Supply pressure	see chart, max. 40 bar
Minimum press. difference	$P_1 : P_2 = 1$ bar
Adjustment	with hexagon socket, with locknut
Relieving function	non-relieving
Gauge port	G $\frac{1}{4}$ on both sides of the body, one screw plug supplied
Mounting position	any, preferably vertical
Temperature range	0 °C to 190 °C / 32 °F to 374 °F medium and ambient temperature
Material	Body, spring cage, inner valve: stainless steel 1.4408 / V4A / 316 L Elastomer and seals: FKM / FPM

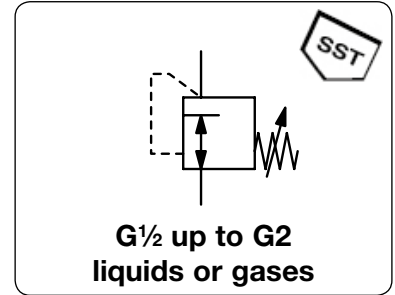

Dimensions			Kv-value (m³/h)*1	Flow rate water l/min	Supply pressure max. bar	Nominal size DN	Connection thread G	Pressure- range bar	Order number
A	B	C							

Regulator with female thread

for liquids, supply pressure max. 25/40 bar non-relieving, 1.4408 / V4A / 316L, FKM

RAI

95	166	29	2,9	50	25	DN 15	G $\frac{1}{2}$	0.2 ... 2	RAI-04A
95	147	29			25			0.5 ... 4	RAI-04B
95	147	29			25			1.5 ... 6	RAI-04C
95	147	29			25			1.5 ... 10	RAI-04D
95	165	29			40			2.0 ... 20	RAI-04F
95	166	29	3,9	65	25	DN 20	G $\frac{3}{4}$	0.2 ... 2	RAI-06A
95	147	29			25			0.5 ... 4	RAI-06B
95	147	29			25			1.5 ... 6	RAI-06C
95	147	29			25			1.5 ... 10	RAI-06D
95	165	29			40			2.0 ... 20	RAI-06F
110	189	39	5,4	90	25	DN 25	G1	0.2 ... 2	RAI-08A
110	157	39			25			0.5 ... 4	RAI-08B
110	157	39			25			1.5 ... 6	RAI-08C
110	157	39			25			1.5 ... 10	RAI-08D
110	176	39			40			2.0 ... 20	RAI-08F
120	189	39	6,1	102	25	DN 32	G1 $\frac{1}{4}$	0.2 ... 2	RAI-10A
120	157	39			25			0.5 ... 4	RAI-10B
120	157	39			25			1.5 ... 6	RAI-10C
120	157	39			25			1.5 ... 10	RAI-10D
120	176	39			40			2.0 ... 20	RAI-10F
150	306	37	9,0	150	25	DN 40	G1 $\frac{1}{2}$	0.2 ... 2	RAI-12A
150	256	37			25			0.5 ... 4	RAI-12B
150	256	37			25			1.5 ... 6	RAI-12C
150	256	37			25			1.5 ... 10	RAI-12D
150	284	37			40			2.0 ... 20	RAI-12F
160	306	37	13,0	150	25	DN 50	G2	0.2 ... 2	RAI-16A
160	256	37			25			0.5 ... 4	RAI-16B
160	256	37			25			1.5 ... 6	RAI-16C
160	256	37			25			1.5 ... 10	RAI-16D
160	284	37			40			2.0 ... 20	RAI-16F



RAI-04...10A

RAI-04...10B/C/D



RAI-04...10D

RAI-12/16A



RAI-12/16B/C/D

RAI-12/16F

Accessories, see opposite side

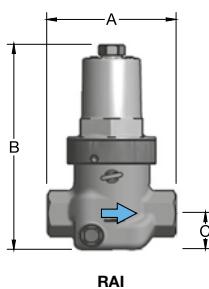

RAI

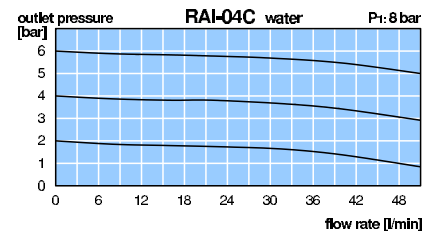
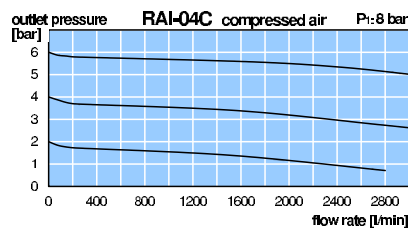

*1 at 8 bar supply pressure, 6 bar outlet pressure and 1 bar pressure drop

*2 for compressed air the flow is 65 times greater

PDF CAD
www.aircom.net



Order example:
RAI-04A

Special



Pressure Regulator for Steam up to 210 °C / 410 °F

RU

Description	Directly acting pressure regulator with stainless steel inner parts suitable for steam and compressed air.	
Media	compressed air, non-corrosive gases or steam with dryness of at least 98%	
Supply pressure	RUG: max. 19 bar at 210 °C / 410 °F, max. 17 bar for red brass version RUH: max. 10 bar at 184 °C / 363 °F	
Air consumption	without constant bleed	
Adjustment	by plastic knob	Relieving function non-relieving
Gauge port	not available	Mounting position any
Temperature range	RUG: max. 210 °C / 410 °F,	RUH: max. 184 °C / 363 °F
Material	Body: spheroidal cast iron EN-GJS-400-18-LT (GGG40.3), optionally red brass Rg5 or stainless steel 1.4404 at RUG Spring cage: epoxy-coated aluminium, nickel-plated aluminium at RUG Inner valve / bellows: stainless steel 1.4404 and 1.4571 O-ring / seal: EPDM and PTFE	

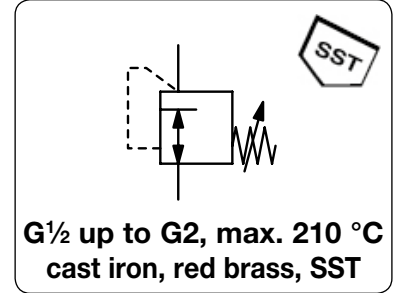

Dimensions			Nominal size	K _v -value	P ₁ max.	Connection thread	Pressure range	Order number
A	B	C	DN	(m ³ /h)	bar	G	bar	

Pressure regulator for steam								RU
								supply pressure max. 10 / 19 bar, non-relieving, spheroidal cast iron
83	182	55	15	1.5	19	G ^{1/2}	0.14...1.7 1.4 ...4.0 3.5 ...8.6	RUG-04A RUG-04B RUG-04C
96	182	55	20	2.5	19	G ^{3/4}	0.14...1.7 1.4 ...4.0 3.5 ...8.6	RUG-06A RUG-06B RUG-06C
108	182	55	25	3.0	19	G ¹	0.14...1.7 1.4 ...4.0 3.5 ...8.6	RUG-08A RUG-08B RUG-08C
134	220	67	25	6.8	10	G ¹	0.14...1.7 1.4 ...4.0 3.5 ...9.0	RUH-08A RUH-08B RUH-08C
134	220	67	40	11.5	10	G ^{1 1/2}	0.14...1.7 1.4 ...4.0 3.5 ...9.0	RUH-12A RUH-12B RUH-12C
134	220	67	50	15.0	10	G ²	0.14...1.7 1.4 ...4.0 3.5 ...9.0	RUH-16A RUH-16B RUH-16C



RUG-04B



RUG-04BSF
made of stainless steel, with flange

Special options, add the appropriate letter

stainless steel 1.4404	body with connection thread	for RUG	RUG-0..S
	body with flange	for RUG	RUG-0..SF
red brass Rg5	body of red brass Rg5, P ₁ max. 17 bar	for RUG	RUG-0..R
flange of spheroidal cast iron	GGG40.3	for RUG	RUG-0..F

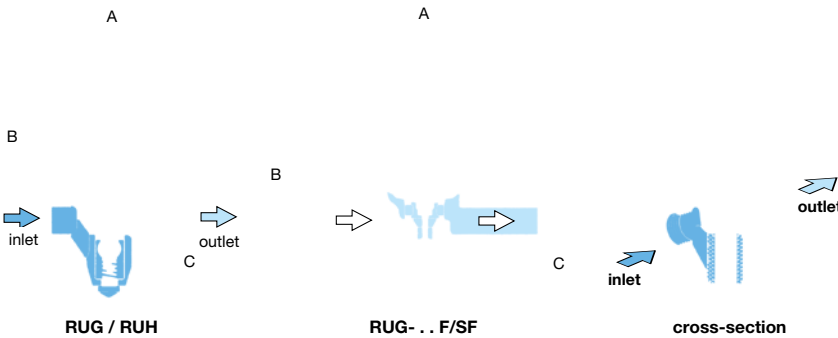
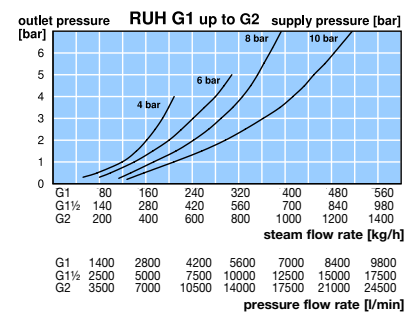
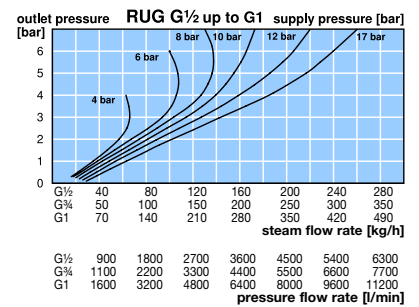

Model	A	B	C
RUG-04R/S	83	192	62
RUG-06R/S	96	192	62
RUG-08R/S	108	192	62

Model	A	B	C
RUG-04F/SF	150	182/192	55/62
RUG-06F/SF	150	192/192	55/62
RUG-08F/SF	160	192/192	55/62

PDF CAD
www.aircom.net

Order example:
RUG-04A